

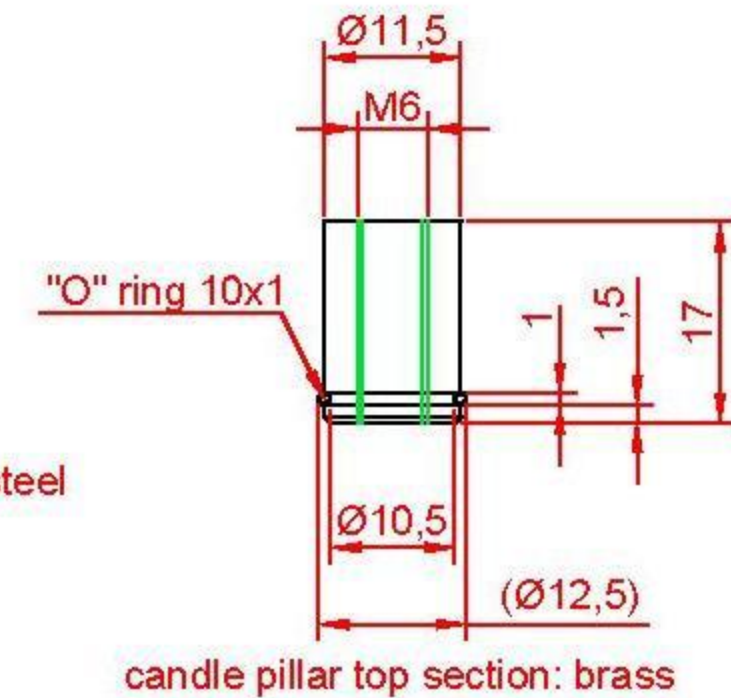

drawn	date	size	scale
J. Jonkman	17-01-2012	A4	
name		Stirling '60'	page
			2 of 9

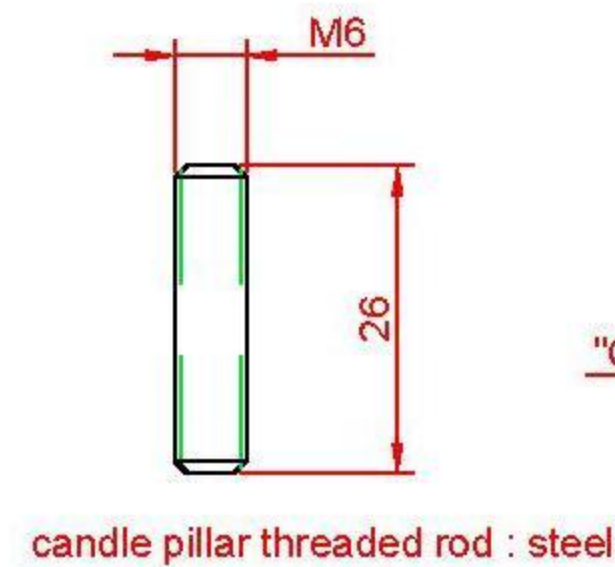

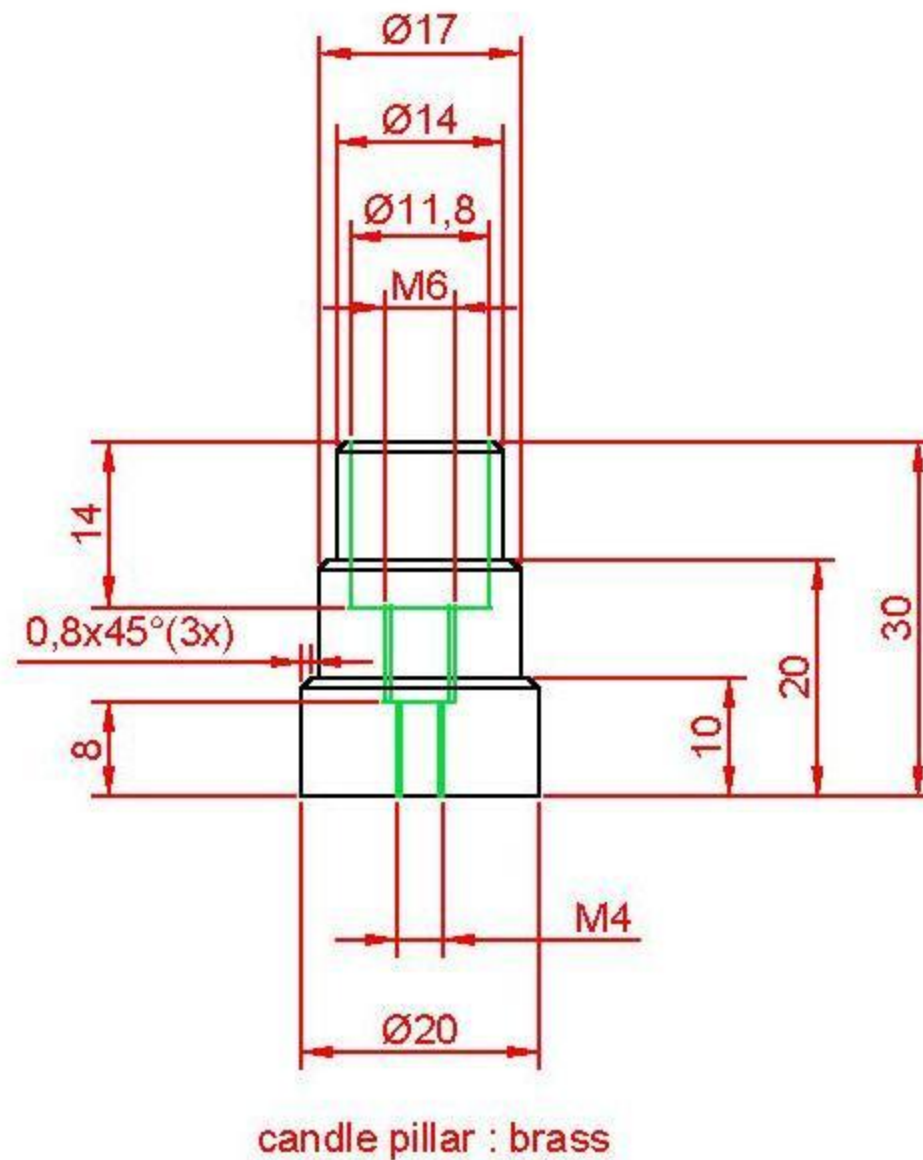
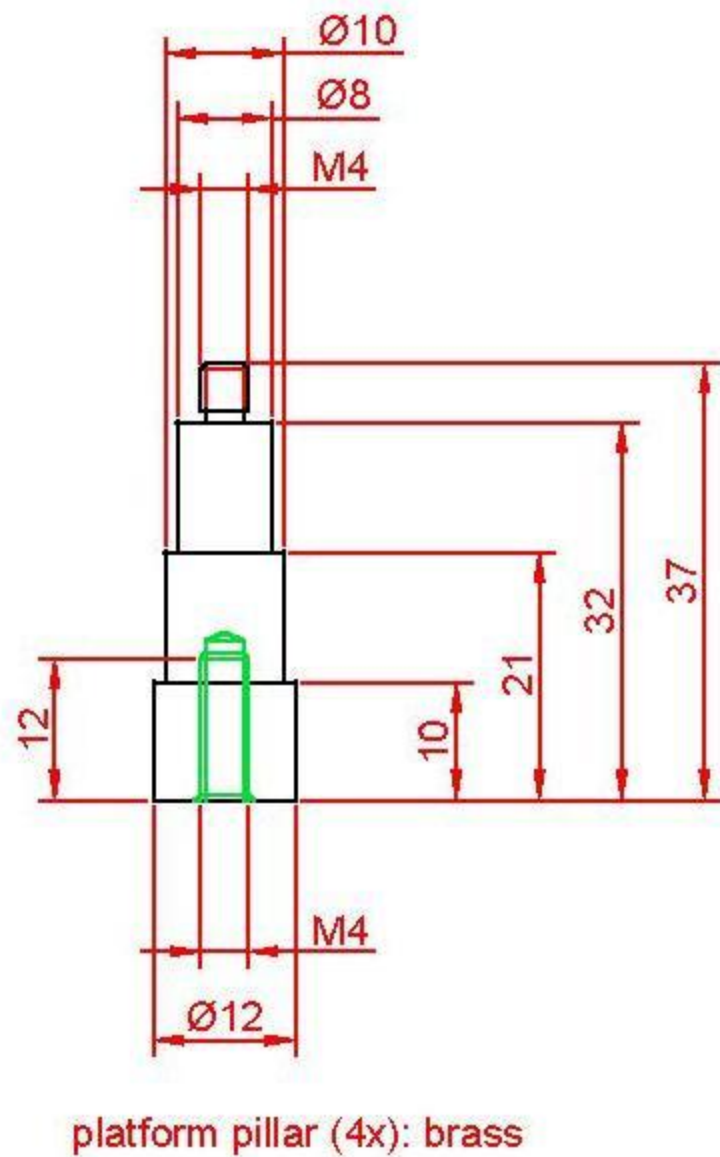
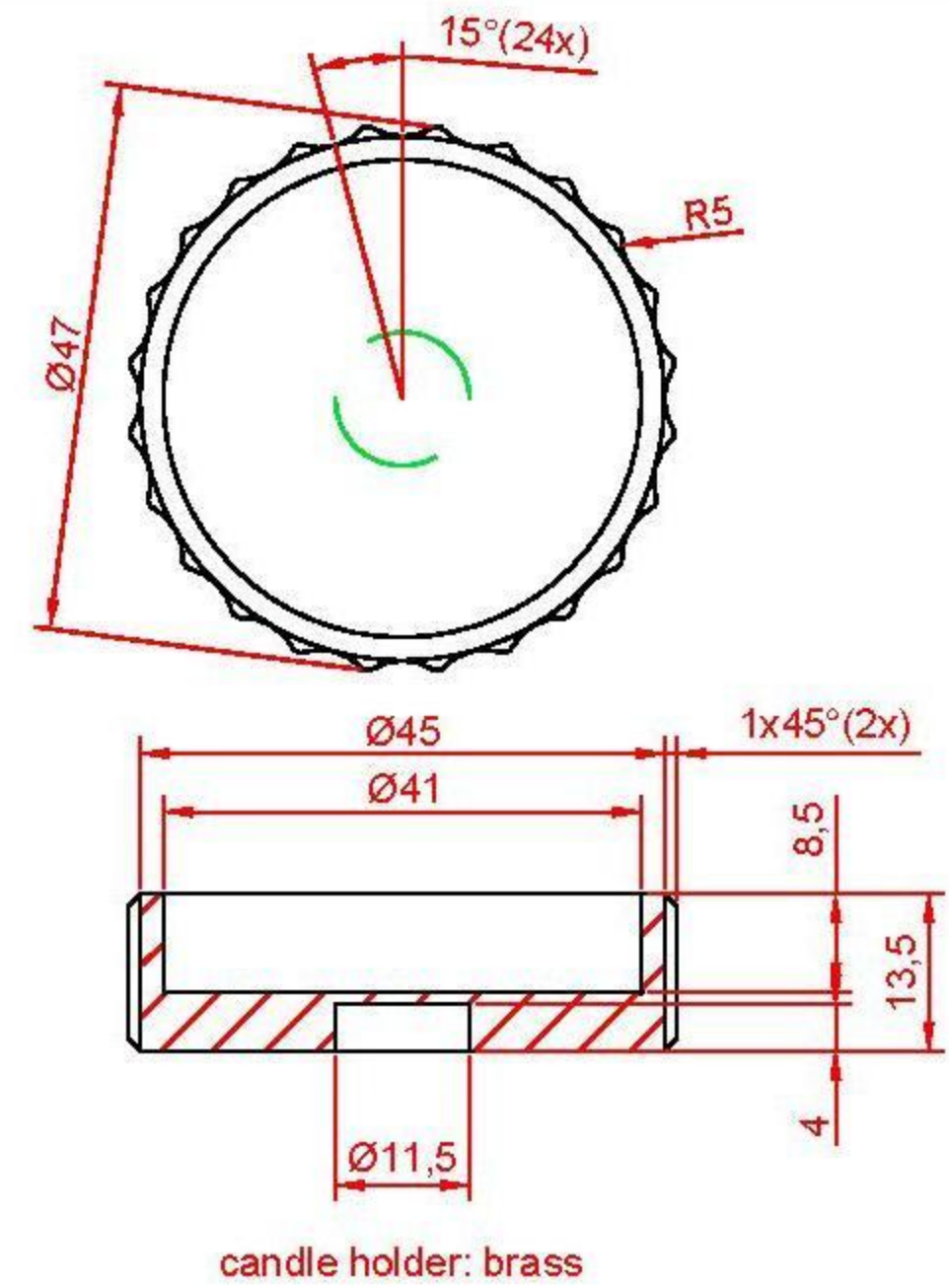
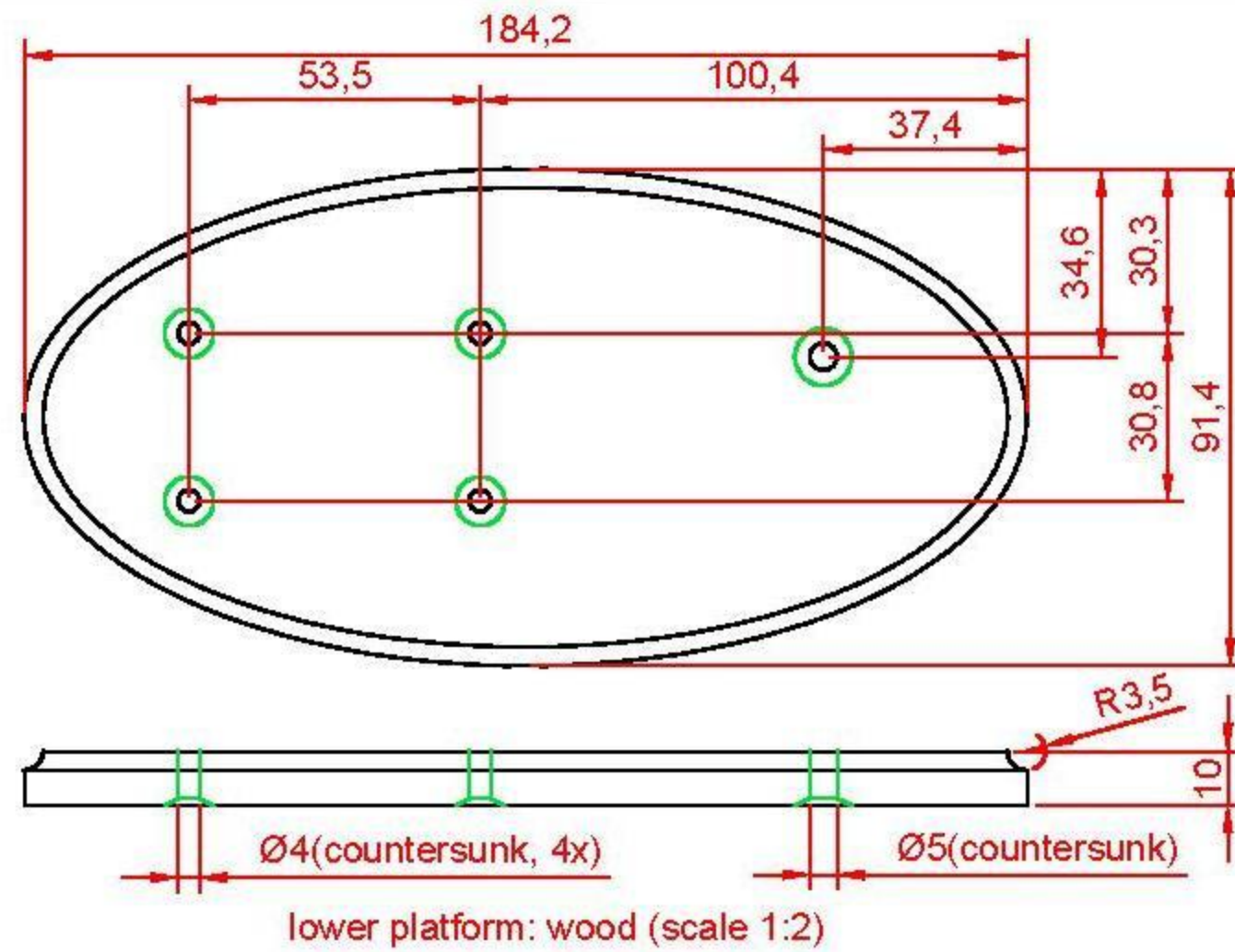
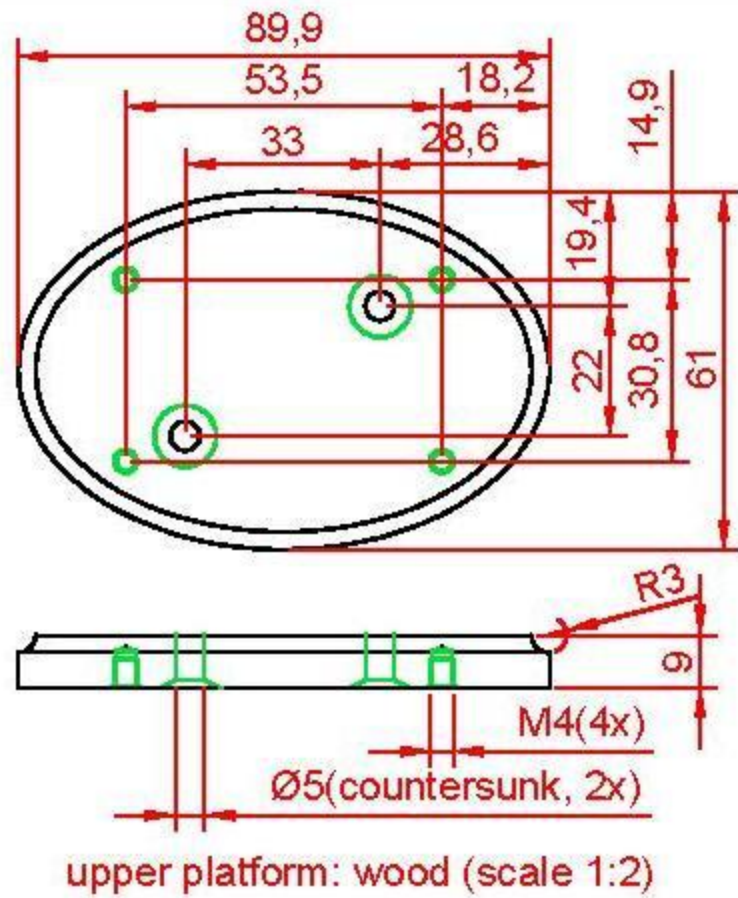

drawn	date	size	scale
J. Jonkman	17-01-2012	A4	1:1 [mm]
name	Stirling '60'		page
			4 of 9



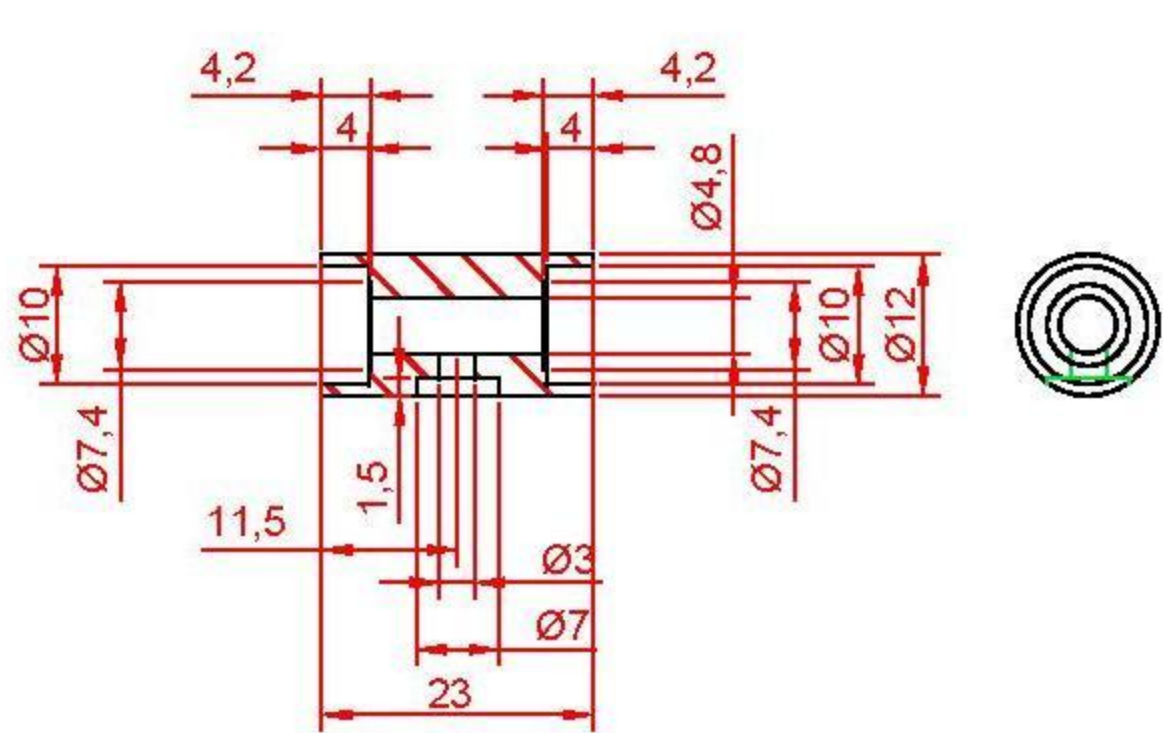

main shaft bearing housing: brass

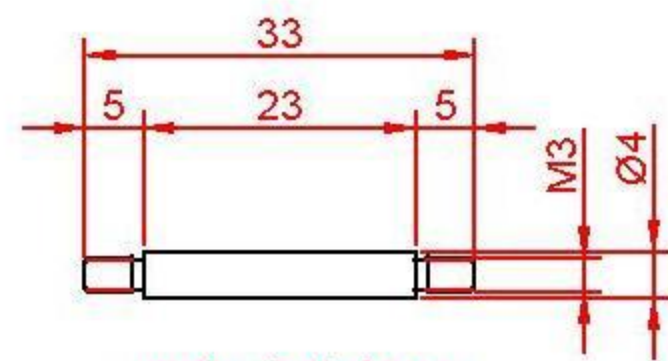

main shaft: brass

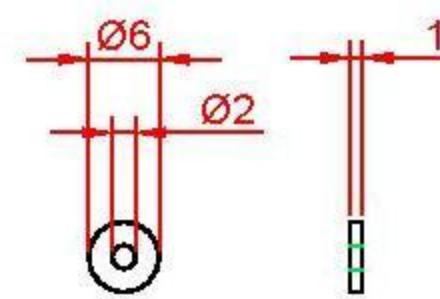

crank spacer: brass

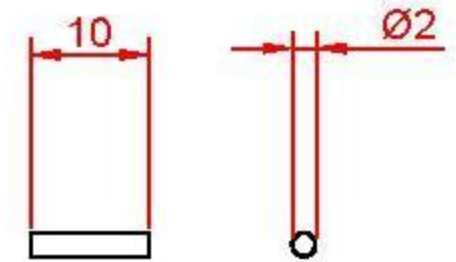

crank rod: brass

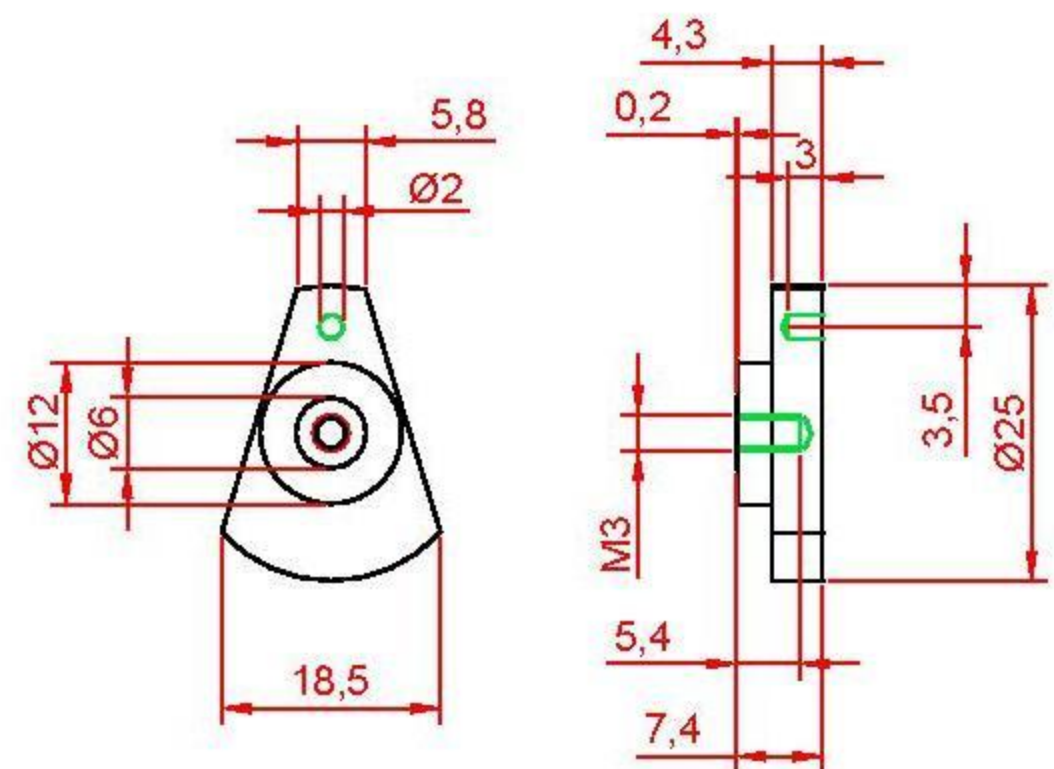

crank: brass

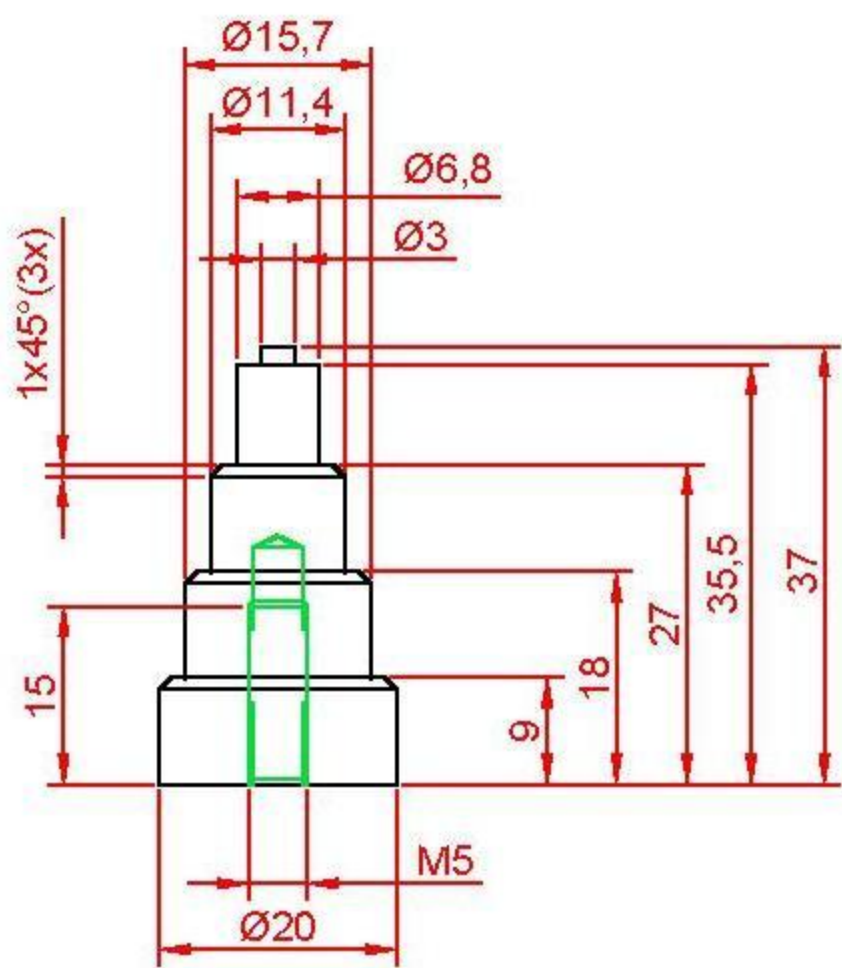

main shaft support pillar: brass

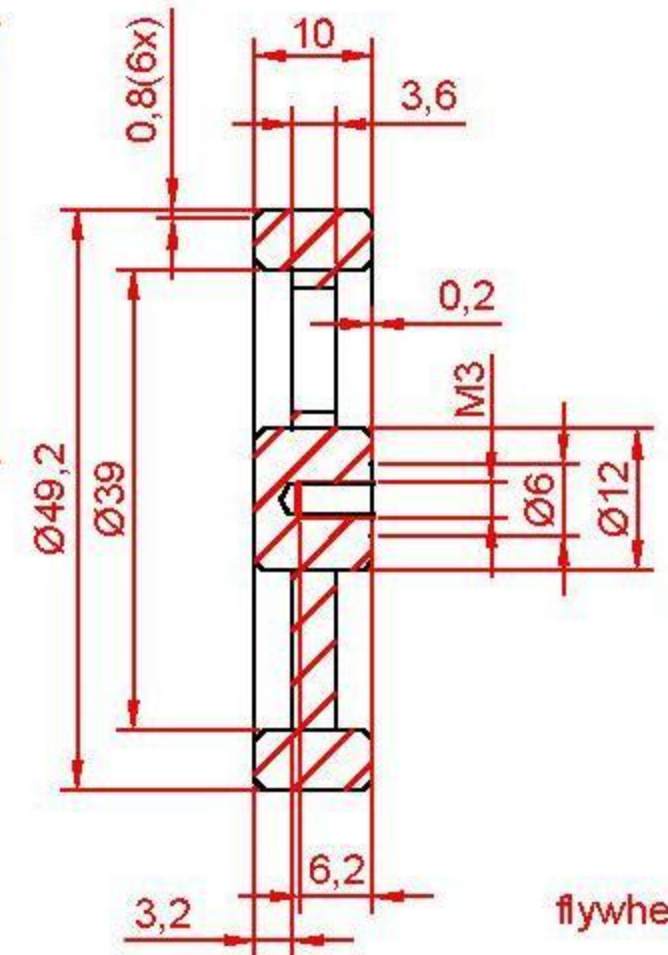

flywheel: brass

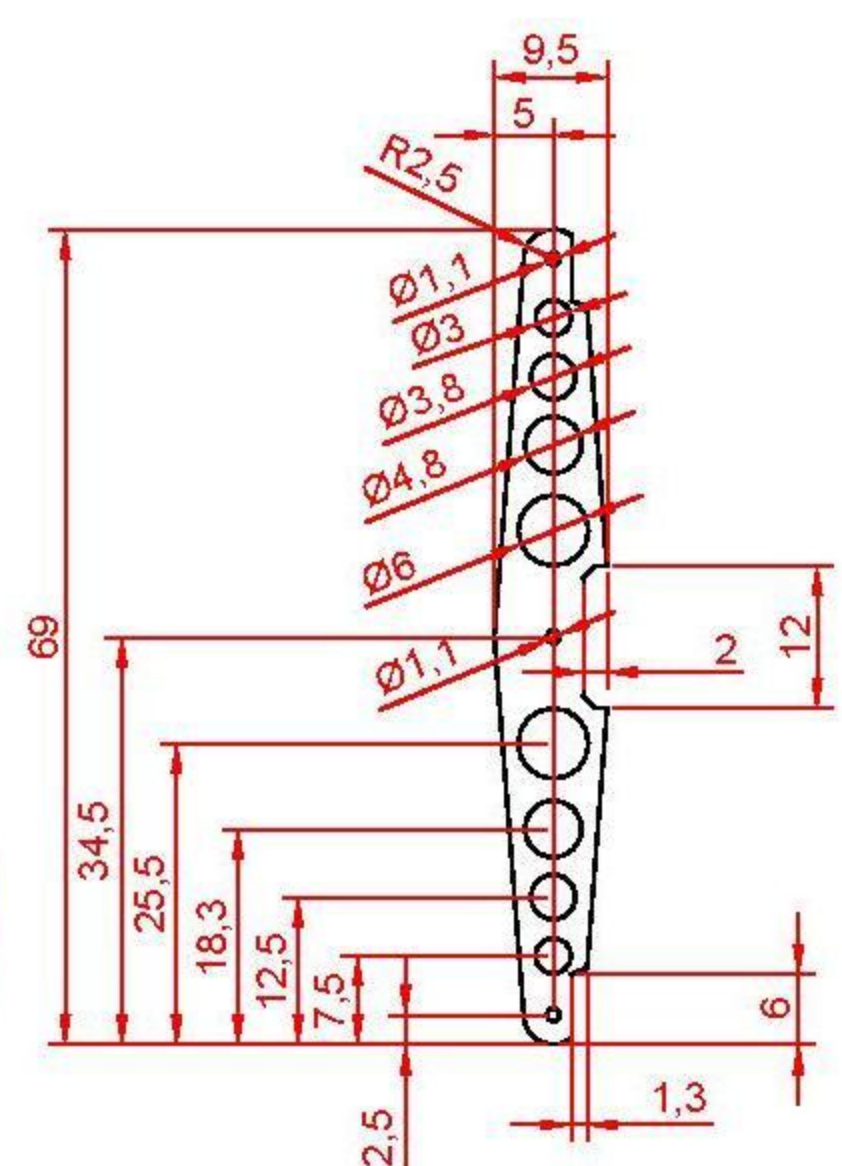
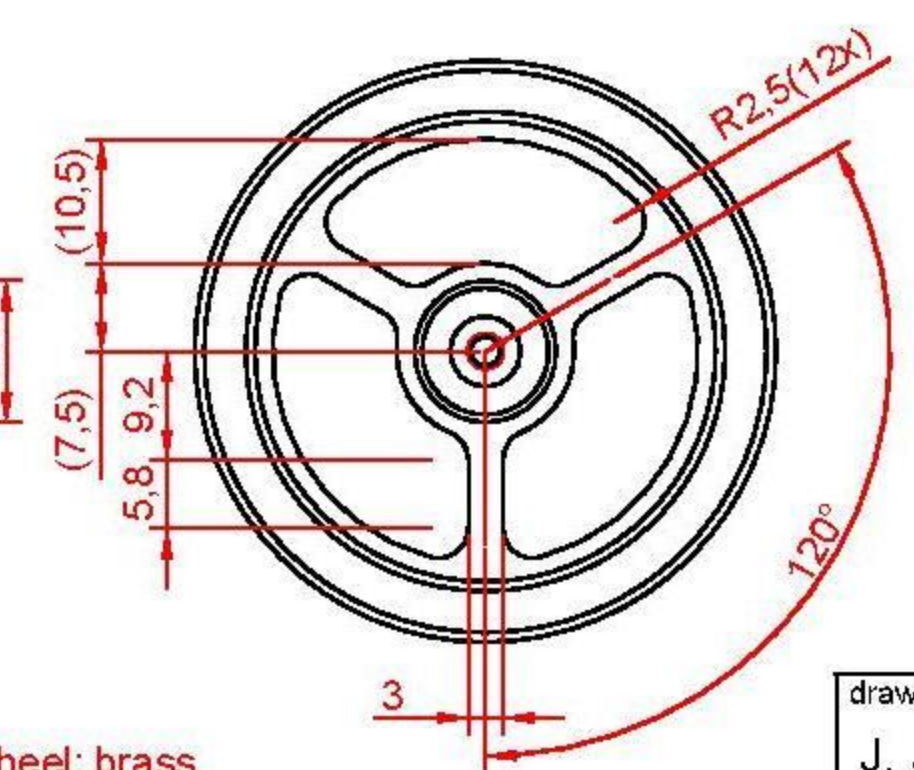

tumbler plate: brass 1.6mm

drawn	date	size	scale
J. Jonkman	17-01-2012	A4	1:1 [mm]
name			page
<b>Stirling '60'</b>			5 of 9



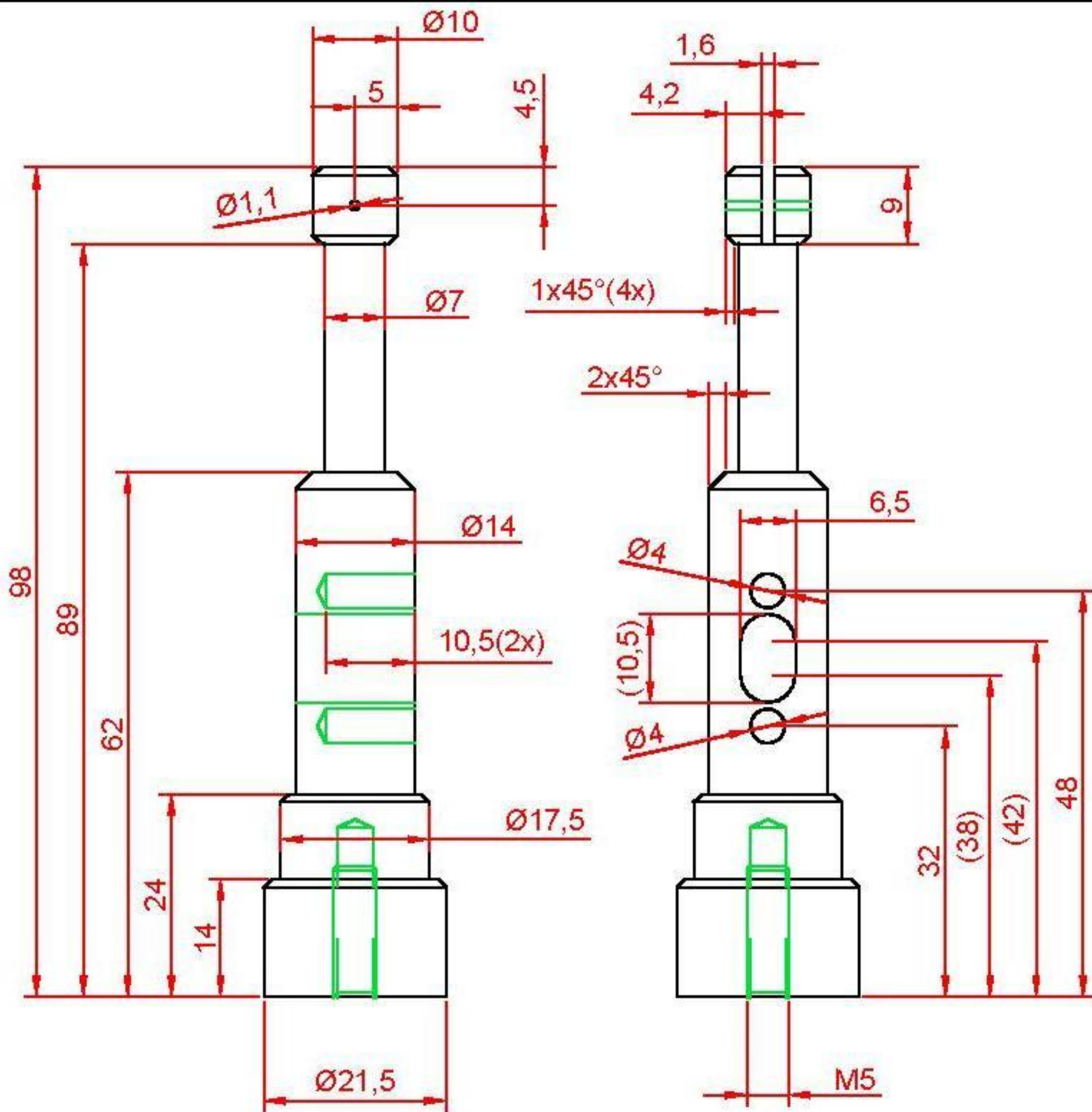

central pillar: brass

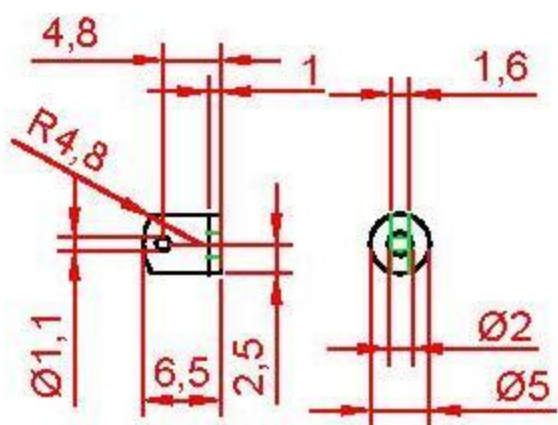

displacer rod end: brass

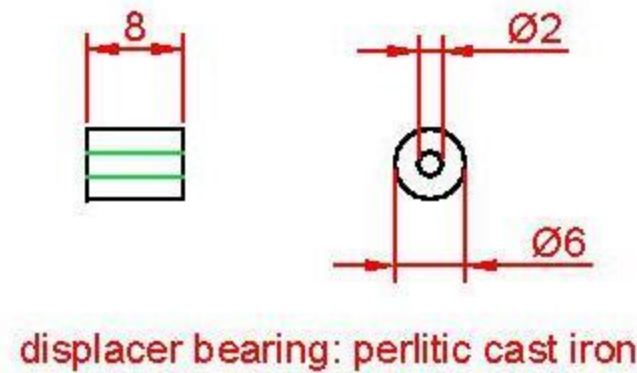

displacer bearing: perlitic cast iron

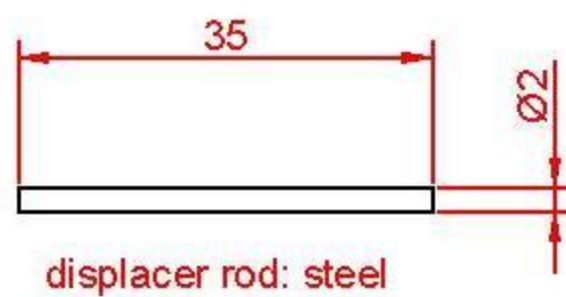

displacer rod: steel

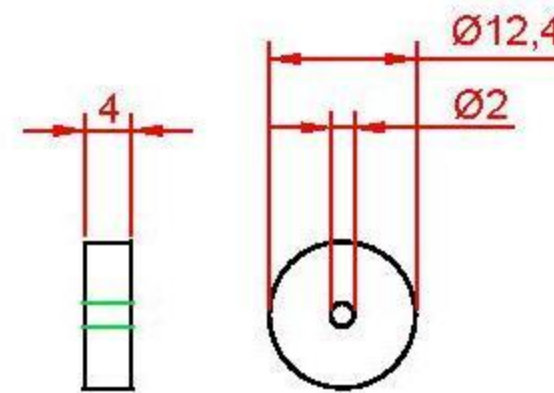

displacer cap: brass



displacer: brass

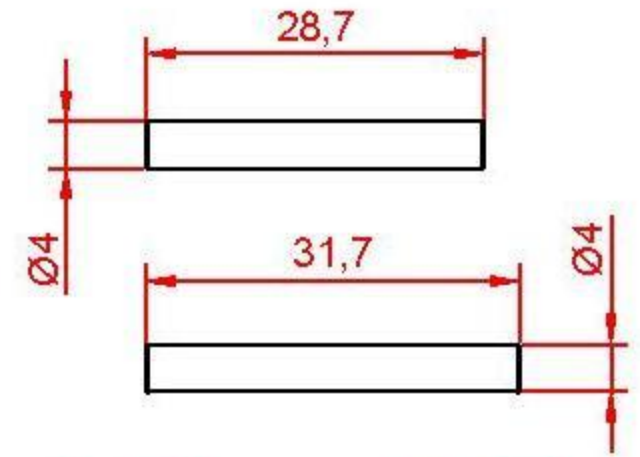

short & long support studs: brass

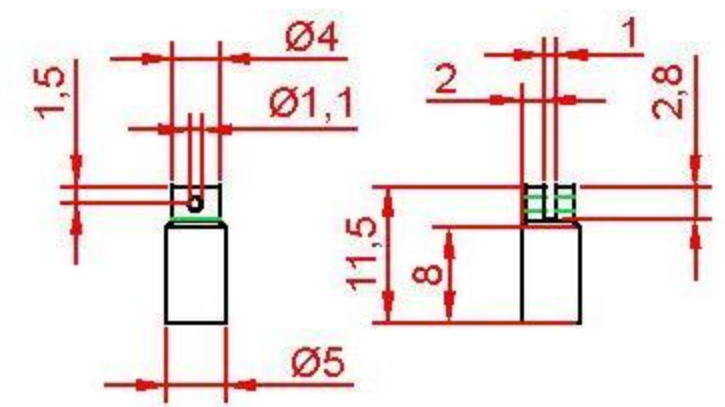

power piston: brass

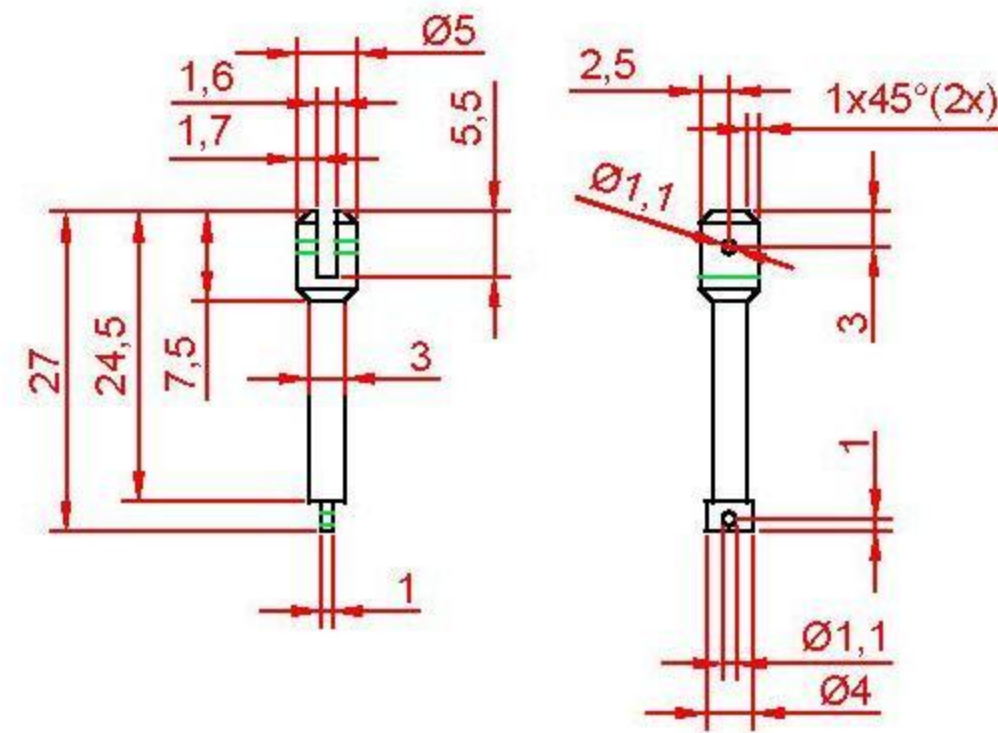

power piston connection rod : brass

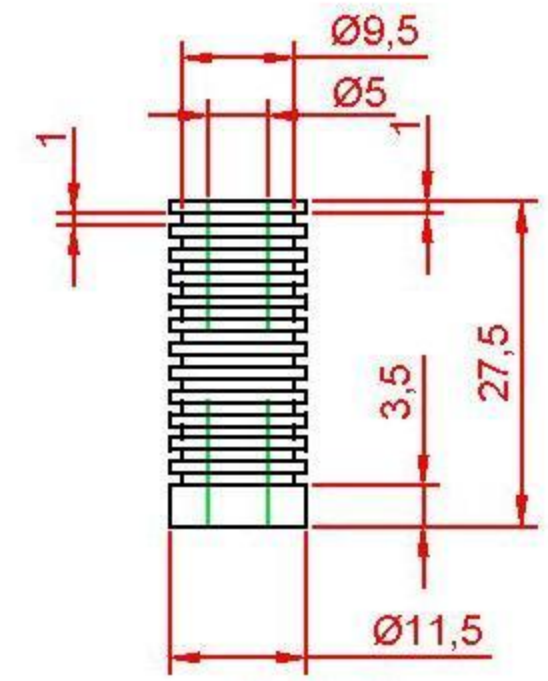

power cilinder: brass

drawn	date	size	scale
J. Jonkman	17-01-2012	A4	1:1 [mm]
name			page
<b>Stirling '60'</b>			6 of 9

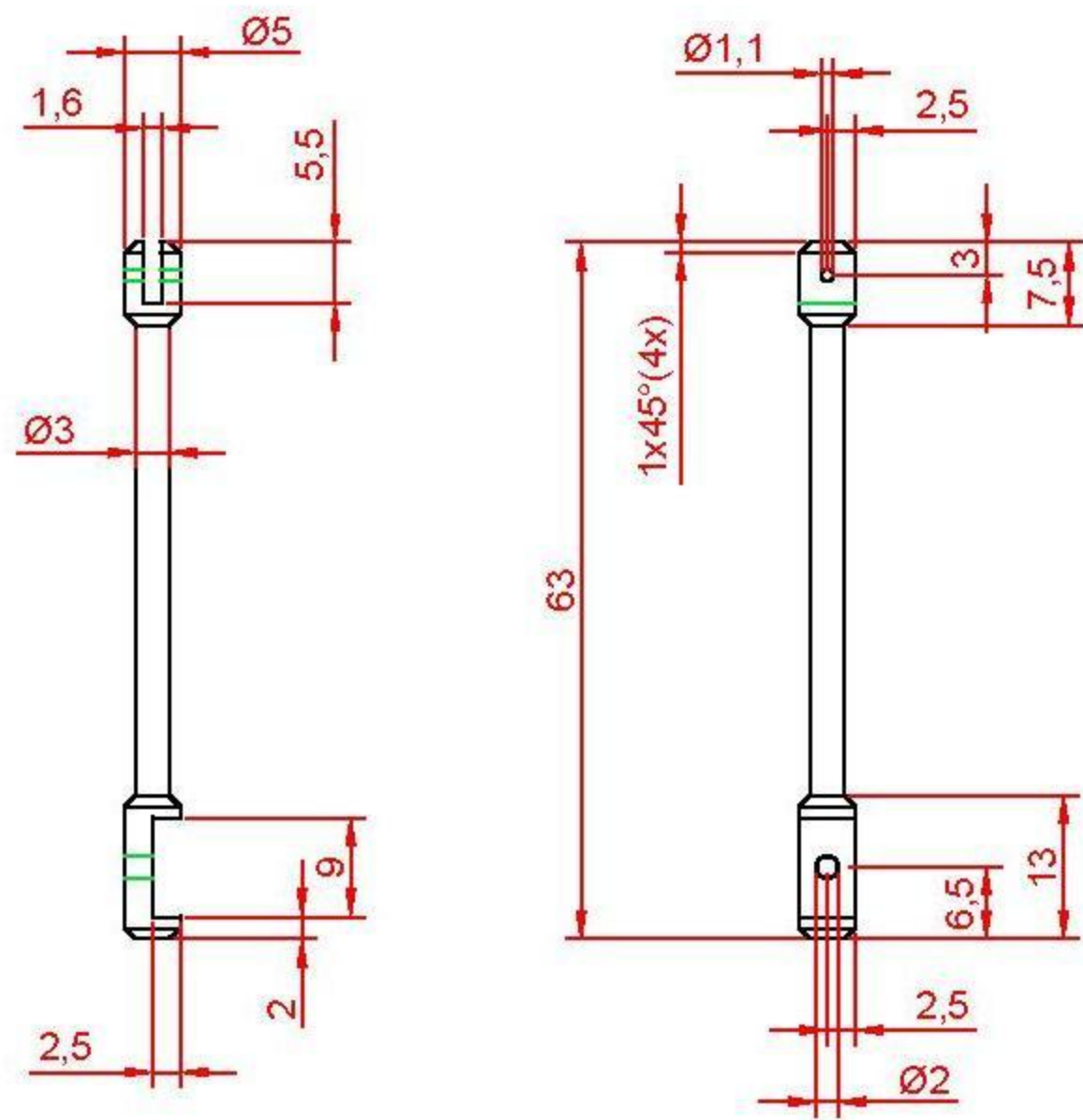

long connection rod: brass

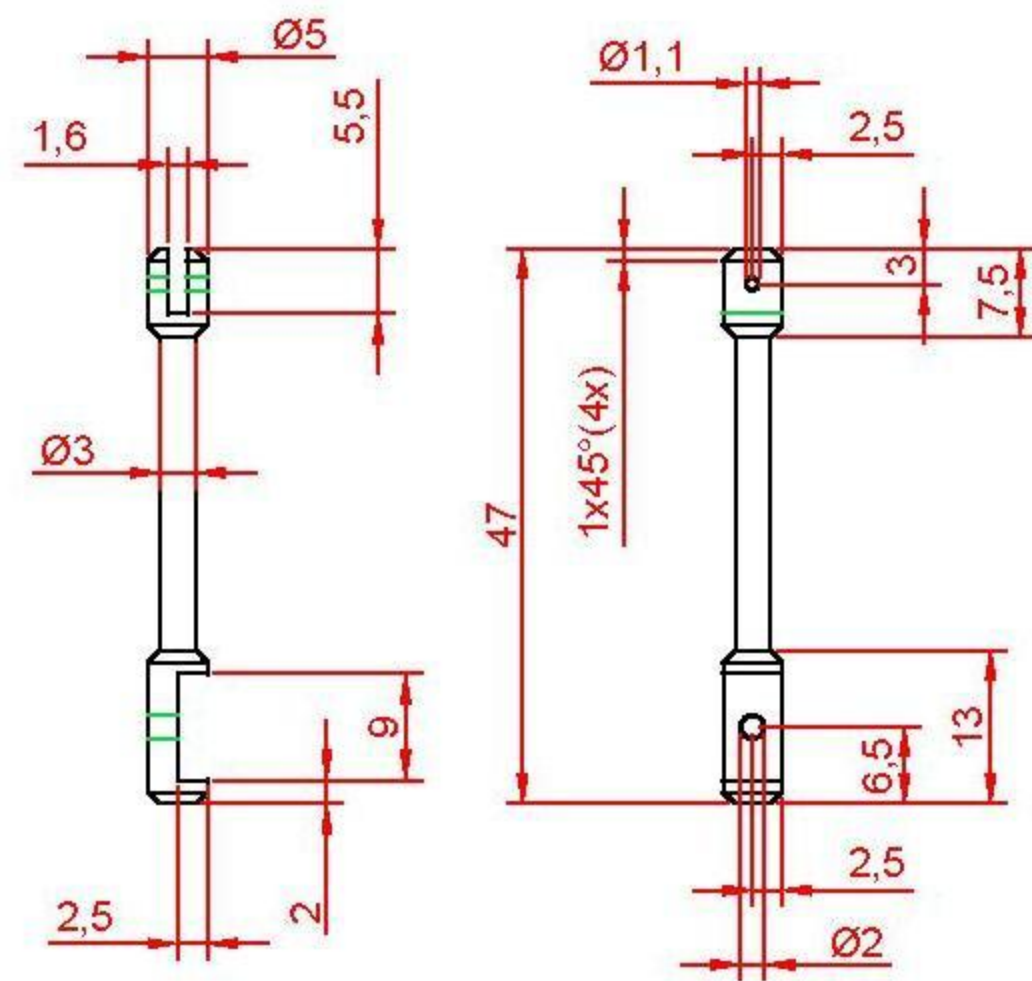

short connection rod: brass

drawn	date	size	scale
J. Jonkman	17-01-2012	A4	1:1 [mm]
name			page
Stirling '60'			7 of 9



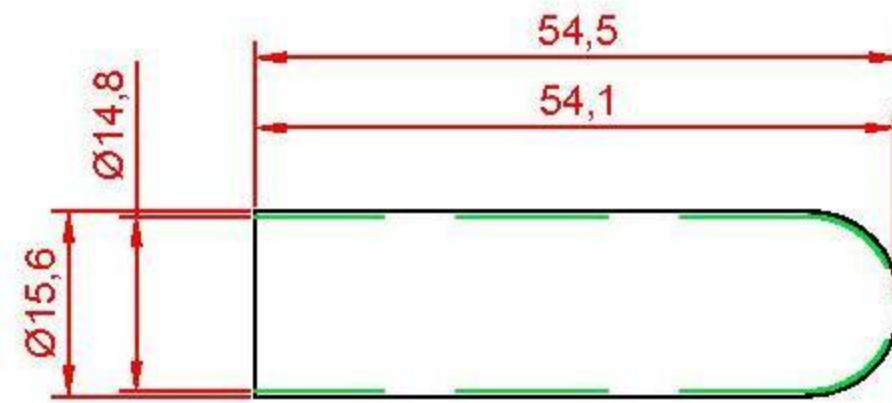

test tube: glass

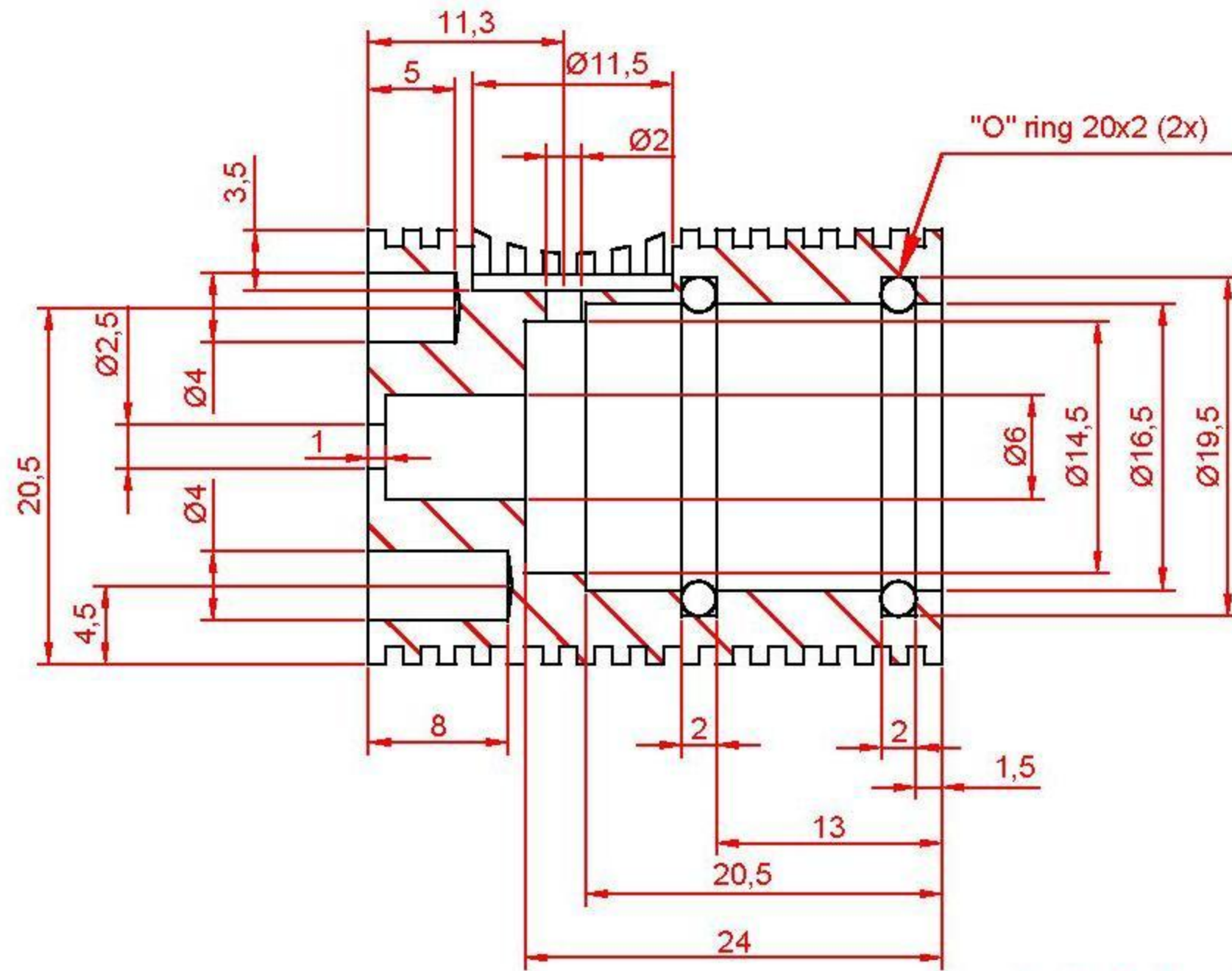

main cilinder: brass (scale 2:1)

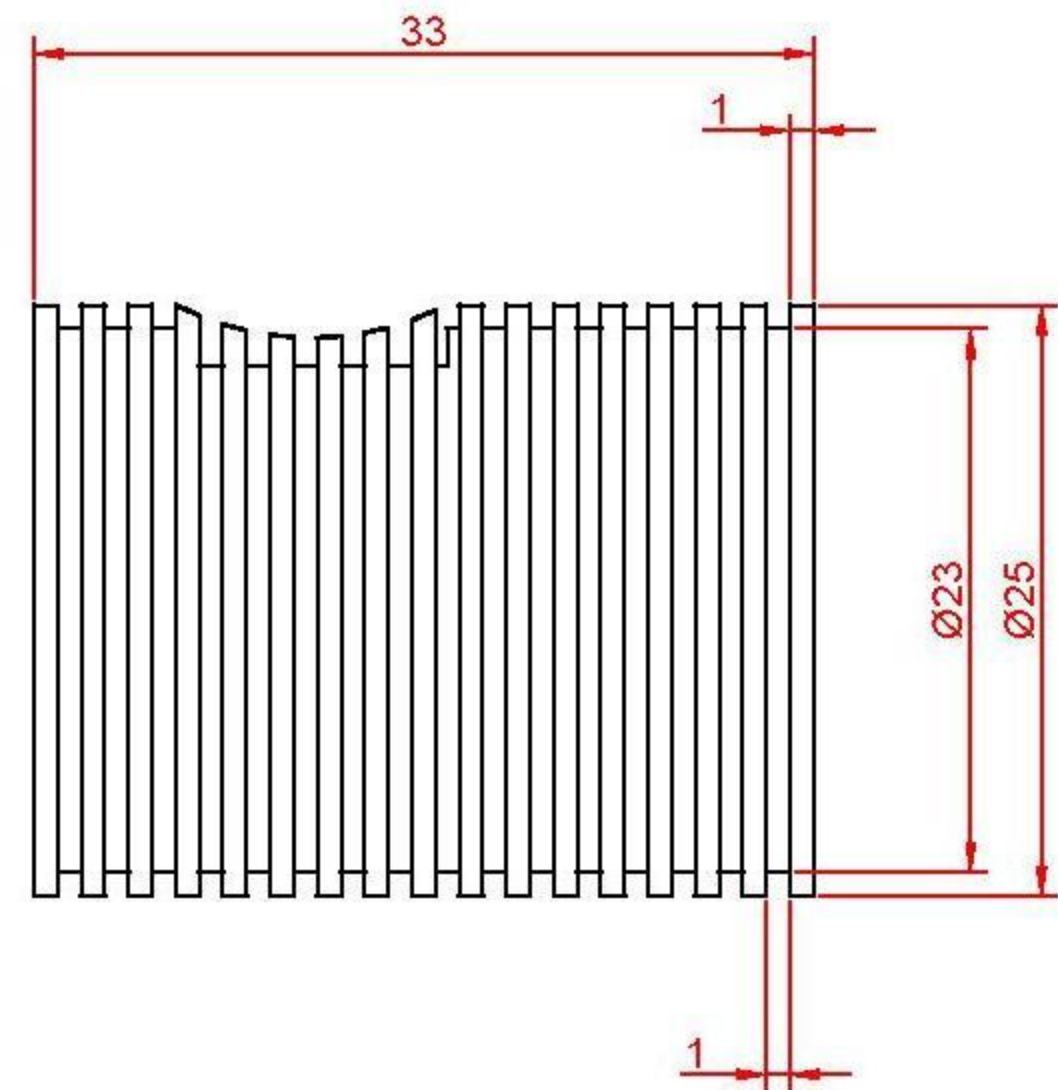

drawn	date	size	scale
J. Jonkman	17-01-2012	A4	1:1 [mm]
name			page
<b>Stirling '60'</b>			8 of 9

- 1) smooth
- 2) Loctite
- 3) pressfit
- 4) solder
- 5) pin

\* see page 9

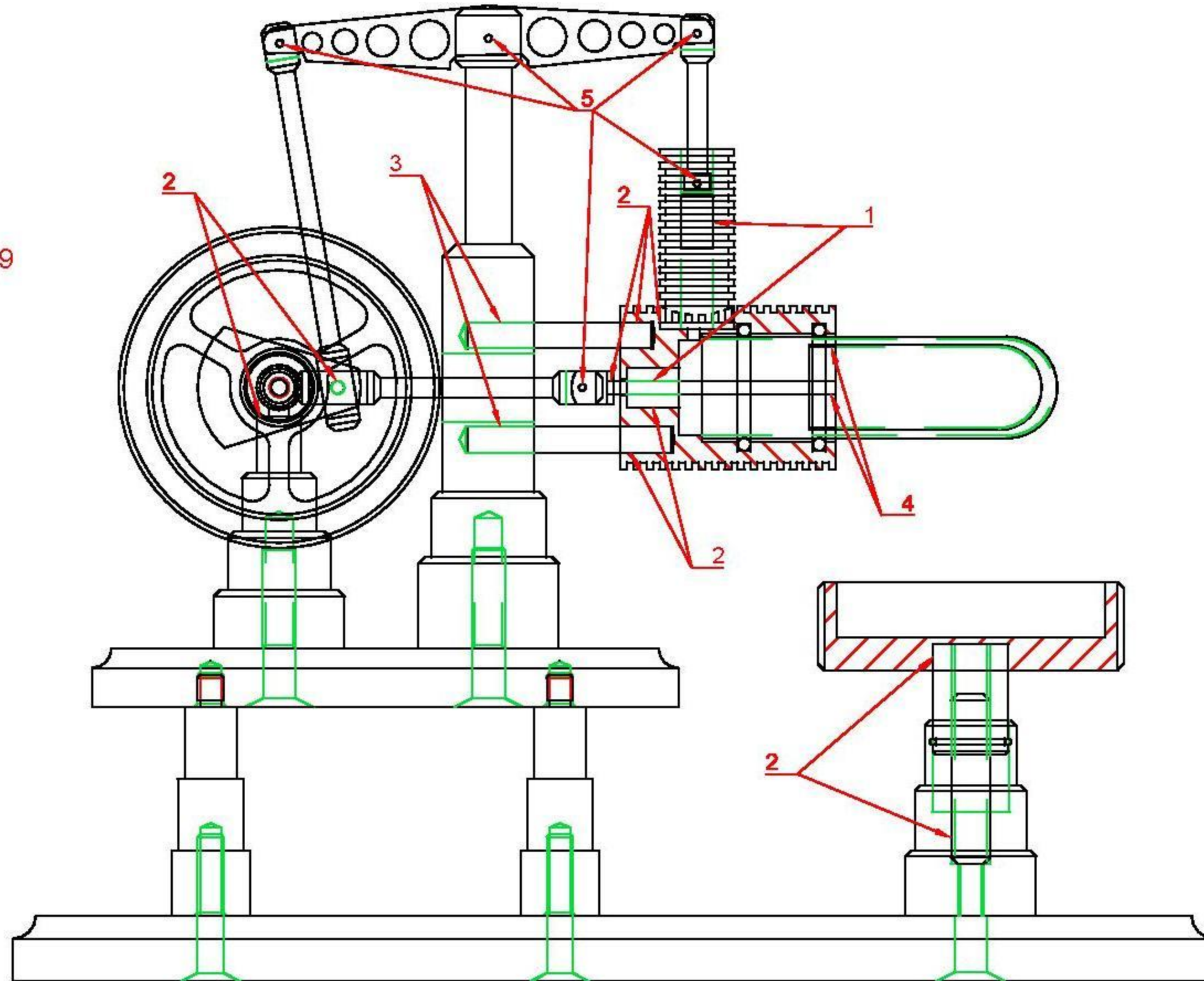

drawn	date	size	scale
J. Jonkman	17-01-2012	A4	1:1 [mm]
name			page
Stirling '60'			3 of 9



- 1) The fitting of the displacer rod and the corresponding bearing is critical; make sure they are smooth and straight. The goal is to get them as air tight as possible, while keeping the friction to a minimum. The same applies to the power piston and the corresponding cylinder. Never lubricate these parts.
- 2) Join these parts with Loctite and wipe off any residue.
- 3) This part of the assembly must be able to be taken apart, therefore a light pressfit is recommended.
- 4) As these pieces are likely to get hotter than Loctite resists, soldering is used.
- 5) Make pins from a straight piece of brass rod, length corresponding with joining parts. Use a very small drop of Loctite on one end to lock the pin in place, but keep the parts moving freely.

The crank spacer is placed over the crank rod, against the crank

If the glass testtube is somewhat different in dimensions, adjust the design of the cylinder holding the testtube and the size of the displacer. The main concern should be the air tight seal of the O rings around the test tube. Also make sure the displacer does not come in contact with any of the parts.

To assemble the testtube in the cylinder, put all parts including the O rings in place and insert a very thin sheet of metal inside the cylinder. Now gently press the testtube inside, while making sure the sheet metal is between the O rings and the testtube. This way the O rings are compressed into place and friction between the O rings and the cylinder is low. After complete insertion of the testtube, gently remove the sheet metal.

Adjust the height of the candle flame by rotating the candle holder. The tip of the flame should be 3mm clear of the testtube.

Apply a small amount of light machine oil or WD40 on moving parts, except for the displacer rod and power piston.

Use 2 open, degreased and cleaned ball bearings for the main shaft, size 10x4x4.

[revision note 17-01-2012] page 7 added (connecting rods), minor dimensioning changes

A video can be found via [www.youtube.com/jeroenjonkman](http://www.youtube.com/jeroenjonkman)

drawn	date	size	scale
J. Jonkman	17-01-2012	A4	1:1 [mm]
name			page
<b>Stirling '60'</b>			9 of 9